

### SYSTEM OVERVIEW

The Telesis® Pinstamp® TMP2100/600 is a high-speed, single-pin marking system that permanently prints messages into a variety of materials such as steel, aluminum, and plastic. A hardened pin is pneumatically accelerated to indent dot matrix characters into the item being marked. The shape, size, density, and location of characters are determined by the user through the system software. The marking head moves the pin cartridge through X- and Y-axis motions to reach the correct position for each dot of the characters to be marked. The system software automatically controls pneumatic pin extension and retraction to mark the message.

The system is compliant with CE, and RoHS specifications.

**The TMP2100 marking head** is an X/Y-traversing mechanism. Using two stepper motor drives, it accurately positions the pin cartridge at coordinate-defined locations in marking window. The TMP2100 uses a rack-and-pinion drive system to rapidly position the pin cartridge and to accommodate the rigorous dynamics of impacting and rebounding.

The floating pin design permits consistent, high-quality marks, even on irregular, slightly curved surfaces. It also accommodates applications where marking surfaces cannot be positioned at a consistent distance from the marker.

**Pin Cartridges.** The standard system uses non-lubricated, lightweight pin cartridges.

**Marking Pins.** for the TMP2100 include the 25S-, 25L-, 25XL, and the 150SA-series. Refer to the TMP2100 Marking Head Installation Manual for pin stroke (pin extension) dimensions. Refer to the marking depth tables for pin cone angles and depths.

**The Marker Cable** connects the marking head to the controller. The highly flexible cable is 4 m (13.1 ft.) long and attaches to the back of the marker with a quick disconnect connector. Optional extension cables lengths are available.

**TMC600 Controller** runs the MerlinTouch PS software and provides the user interface for operating the marking system. The controller features an integrated, 10-in., high-resolution, touch screen monitor in the top panel. The back panel of the controller provides the electrical interface for connecting to optional, remote I/O sources. There is also a TMC600P panel version for use with an enclosure unit See *TMC600 Controller Specifications* for details.

The **Filter/Regulator Unit** includes two regulators with pressure gauges to control drive air and return air. The first regulator contains a filter to help remove contaminants from the supply air. Two air lines connect the regulated air to the marking head. Drive air fires the impact pin; return air pushes it back into the cartridge. Standard air lines are 4 m (13.1 ft.) long made of 6 mm tubing.

# TMP2100/600 Marking System

---

---

## SYSTEM OPTIONS

- Backup Utility Software
- Bar Code Scanner
- Bar Code Wand
- Logo/Font Generator Software
- Marking Head Extension Cables
- Upgrade Utility Software
- TMC600 Controller Wall-mounting Bracket Kit
- TMC600P Panel mount option
- Tool Post Assembly
- USB Mouse
- USB Keyboard

## SYSTEM SETUP

Complete installation procedures are provided in the *TMP2100* and the *TMC600 Installation/Maintenance Manuals*. The following procedures are listed for reference only to provide a general overview of the installation process.

1. **FIXTURE-MOUNTED MARKERS** . When designing a fixture, allow for 3-axis adjustment to aid in horizontal, vertical, and lateral alignment of the marking head.
  - ▶ Mount marking head to a suitable fixture using four M8-1.25 bolts. **Mounting bolts must not extend into marking head more than 10 mm (0.394 in.).**
2. Mount filter/regulator assembly, using brackets provided, within 4 m (13.1 ft.) of marking head.
3. Connect drive air and return air lines to the connectors on back of marking head.
4. Connect supply air to input port on filter/regulator assembly.

### CAUTION

The TMC600 is not a sealed unit. Protect it from potentially damaging conditions and contaminants. Do not block vents in bottom of case. Ensure the marking system is electrically isolated from any devices that may generate extreme electromagnetic interference (EMI).

5. Locate controller as close as practical to marking head. Standard marker cable length is 4 m (13 ft.).
6. Install the controller as a table-top, wall-mounted, panel-mounted, or enclosure-mounted unit, as applicable.
7. Ensure controller power switch is OFF.
8. Connect marker cable to controller.
9. Connect power cable to controller.
10. Position controller power switch to ON.
11. Start marking system software.
12. Adjust pin stroke, drive air, and return air for impact depth.

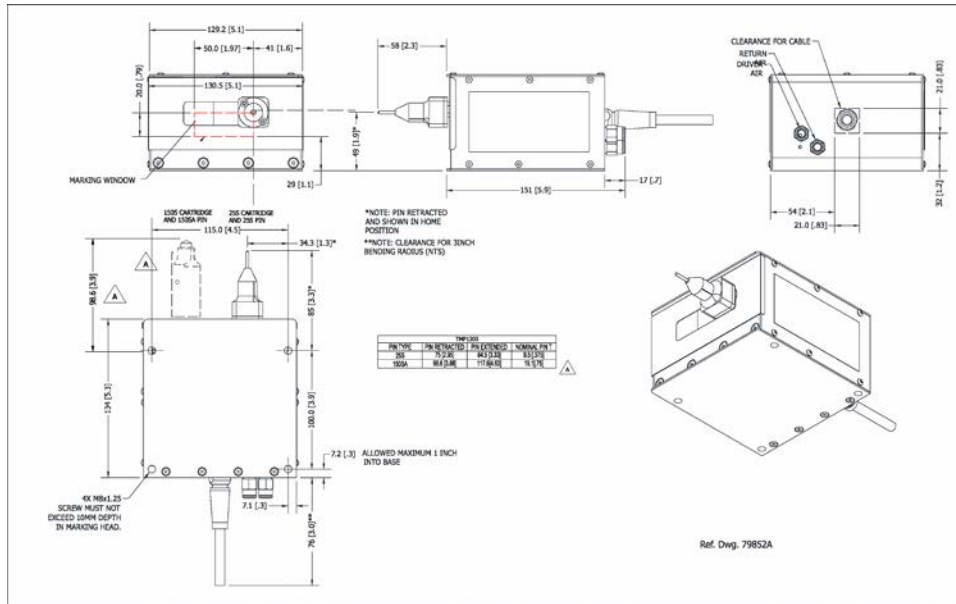

**TMP2100 Fixture-Mounted Marking Head Dimensions**

## TMP2100 MARKING HEAD

### Specifications

The TMP2100 marking head specifications are subject to change without prior notice.

Dimensions.....	refer to the appropriate <i>TMP2100 Marking Head Dimensions</i> drawing
Rating .....	NEMA <sup>®</sup> 2 (I.P. 41) with optional, protective debris shield installed
Weight	
Fixture-mounted .....	1.81kg (4 lb) excluding cable, handle, standoff, and tooling
Operating Temp. ....	0° to 50°C (32° to 122° F), non-condensing
Air Supply .....	Clean and dry, 2.8 to 6.9 bar (40 to 100 psi)
Air Consumption.....	0.019 L/sec (0.04 SCFM) idle 0.37 L/sec (0.8 SCFM) marking
Marking Area .....	50 x 20mm (1.96 x .79 in.)
Pin Types .....	25S-series, 25L series 150SA-series, 25XL series
Pin Material	
25S-series .....	Powdered Metal or Stainless Steel with Diamond Tip or Carbide
150SA-series.....	Powdered Metal or Tool Steel with Carbide Tip
25SC series .....	Powdered Metal or Stainless Steel or Carbide with Diamond Tip

### Marking Characteristics

The TMP2100 can produce characters as small as 0.75 mm (0.03 in.) high. Text strings may be rotated 180° to print inverted. Characters can be printed with resolutions from 4 to 79 dots/cm (10 to 200 dots/in.) for an engraved look. The depth of mark can be adjusted over a significant range by adjusting the pin stroke and, to a lesser extent, by adjusting the drive air pressure.

### Marking Speeds

The system can mark 3 mm (0.118 in.) high characters in the 5x7 font at a rate of 4 characters per second. Speeds will vary widely depending on the selected character size, style, and dot density. Specific times can be verified by a Telesis representative.

### Marking Noise

Although every attempt is made to reduce noise, the material being marked significantly influences the noise level. For example, marking a solid lead block produces less noise than marking a thin-walled steel pipe.

### Pin Life

Pin life depends largely on the type of material being marked, how hard or abrasive it is, and the required marking depth. On typical metals with a hardness of Rockwell Rb47, marking at a depth of .127 mm (0.005 in.), powdered metal pins average about 3 million impressions before needing sharpened. Carbide pins average about 9 million impressions.

# TMP2100/600 Marking System

---

## Marking Depth

The following tables provide sample marking depths. Drive air was set at 80 psi (5.5 bar); return air was set at 20 psi (1.4 bar); pin stroke was set to the maximum allowable distance for each pin type to achieve the maximum depth of mark.

<b>NOTICE</b>
---------------

The recommended nominal drive air pressure is 80 psi (5.5 bar). Lower drive air pressure may be used, but will result in decreased depth of mark and increased cycle time.

### Depth – Type 25S Powdered-Metal Pins

MATERIAL (HARDNESS)	22° CONE	30° CONE	45° CONE	60° CONE
Aluminum (Rb3)	.006 in. .127 mm	.009 in. .178 mm	.012 in. .279 mm	.016 in. .406 mm
Brass (Rb18)	.005 in. .076 mm	.007 in. .127 mm	.011 in. .229 mm	.012 in. .305 mm
Cold Rolled Steel (Rc18)	.004 in. .076 mm	.006 in. .127 mm	.010 in. .203 mm	.012 in. .305 mm

### Depth – Type 25SC Carbide Pins

MATERIAL (HARDNESS)	22° CONE	30° CONE	45° CONE	60° CONE
Aluminum (Rb3)	.008 in. .152 mm	.009 in. .178 mm	.012 in. .254 mm	.011 in. .279 mm
Brass (Rb18)	.005 in. .127 mm	.007 in. .178 mm	.011 in. .203 mm	.009 in. .229 mm
Cold Rolled Steel (Rc18)	.004 in. .010 mm	.006 in. .127 mm	.010 in. .178 mm	.009 in. .229 mm

### Depth – Type 150SA Pins

MATERIAL (HARDNESS)	22° CONE	30° CONE	45° CONE	60° CONE
Aluminum (Rb3)	N/A	.012 in. .203 mm	.015 in. .305 mm	N/A
Brass (Rb18)	N/A	.011 in. .178 mm	.013 in. .254 mm	N/A
Cold Rolled Steel (Rc18)	N/A	.010 in. .152 mm	.012 in. .203 mm	N/A

## TMC600 CONTROLLER

The TMC600 controller may be installed as a table-top unit, wall-mounted unit, or panel-mounted unit. All configurations provide features and connectivity for external communications. Differences occur only in the mounting configuration.

### TMC600 Specifications

The TMC600 Controller specifications are subject to change without prior notice.

Integrated Processor.....	Intel® Dual-Core Atom™
Integrated Monitor.....	10.1 in., color, 1024 x 600, capacitive touch screen LCD
Compliance.....	CE
Rating.....	NEMA 1 (I.P. 30)
Configurations.....	Table-top or wall-mounted
Dimensions.....	see <i>TMC600 Controller Dimensions</i> drawing
Weight.....	7.00 lb. (3.18 kg) controller only 7.21 lb. (3.28 kg) with wall-mount kit
Operating Temp. ....	32° to 104° F (0° to 40°C)
Operating Humidity.....	10% to 80% non-condensing
Power Requirements.....	115/230 VAC, 3/1.5 amps, 50/60 Hz, single phase

Cooling.....	Internal, thermostatically controlled fan
Filtering.....	Integrated, 60 ppi contaminant filter
Communications.....	RS232, TTL, Discrete I/O, TCP/IP, and USB (for data backup & transfer)
Input Signals.....	Twelve (12) total, optically isolated 8 dedicated, 1 programmable, 3 available  10 VDC minimum voltage 30 VDC maximum voltage 12 to 24 VDC nominal voltage 2.3 mA @ 12VDC nominal current 4.9 mA @ 24VDC nominal current
Output Signals.....	Six (6) total, optically isolated 3 dedicated, 3 available  0.25 amps maximum current 0.50 ohms maximum On resistance 40 VDC maximum line voltage 12 to 24 VDC nominal line voltage

### TMC600P Specifications

The TMC600P controllers specifications are the same as the TMC600 except for the following.

Rating.....	NEMA 3 (I.P. 64) when installed in NEMA 3 rated enclosure
Filtering.....	none

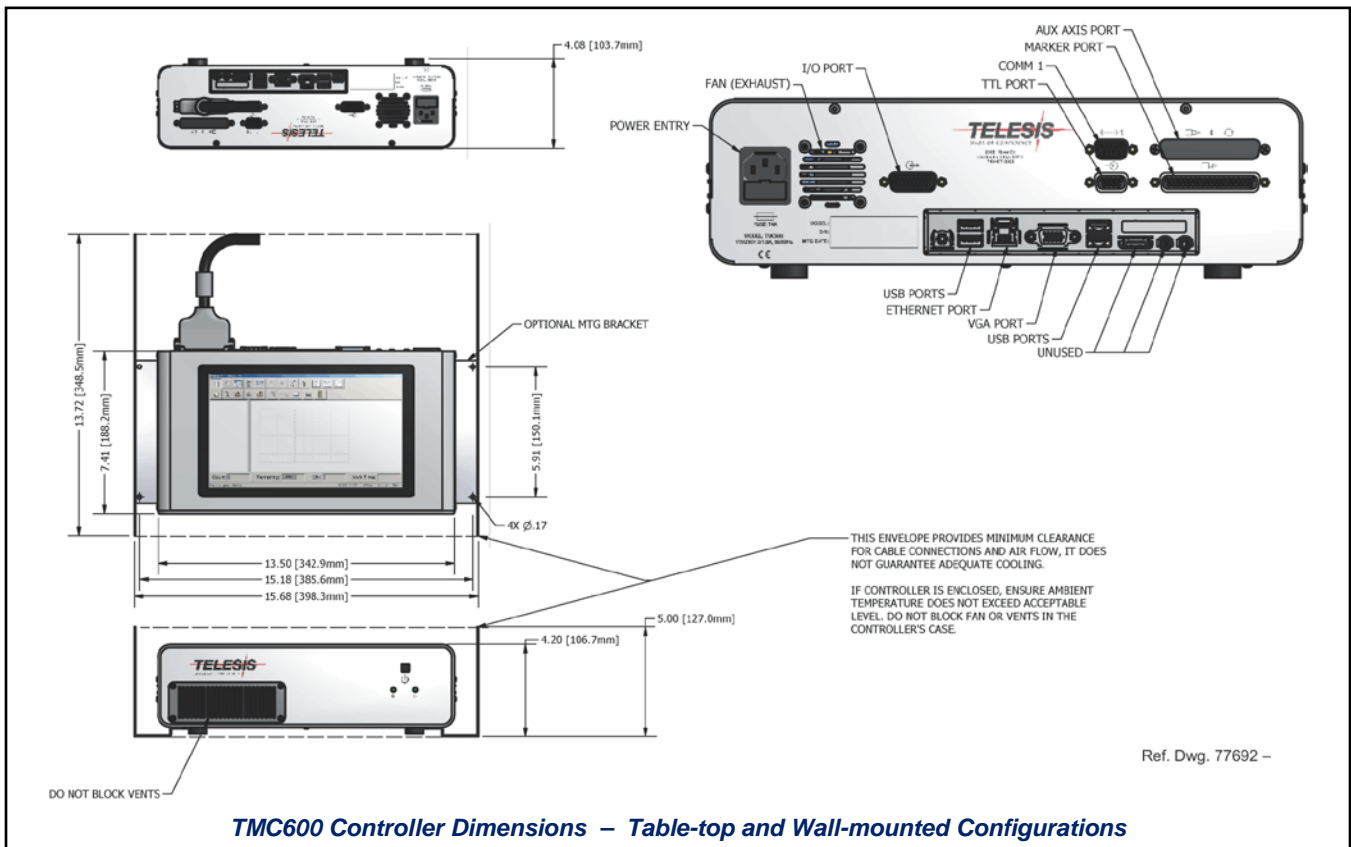

## TMP2100/600 Marking System

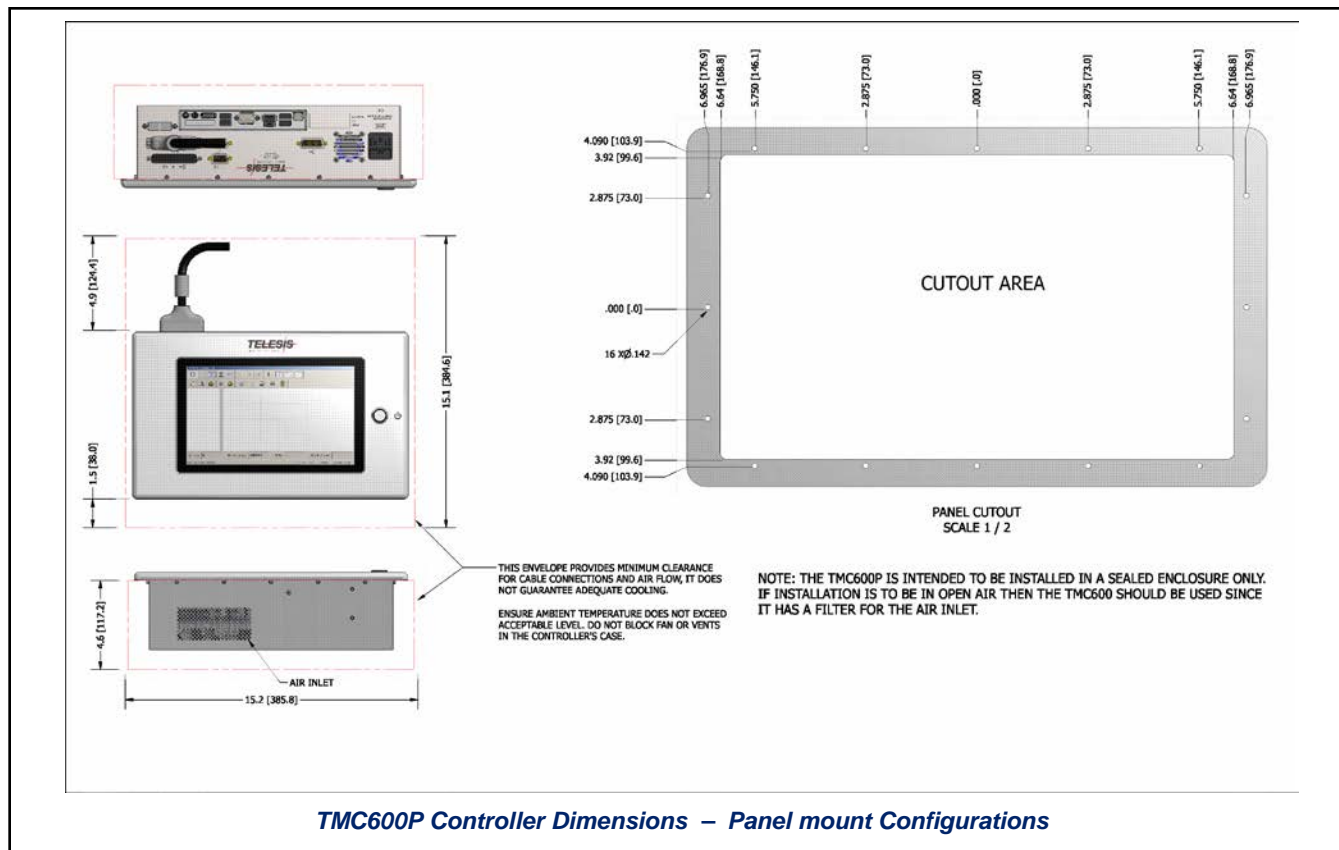

### Environmental Considerations

The following environmental considerations must be taken into account when installing the TMC600 Controller.

**Contaminants.** The vented TMC600 is rated NEMA 1 (IP30) and contains a thermostatically-controlled, variable speed fan. It also incorporates a 60 ppi filter which will filter most common contaminants. However, in certain environments, the possibility exists that contaminants can be drawn into the TMC600 controller and possibly result in failure. For that reason, in these types of environments, the controller must be located in a sealed industrial enclosure. . The TMC600P has no filter since it will be mounted inside of an enclosure.

**EMI Susceptibility.** Although the system has been found to be in compliance with pertinent susceptibility standards, care should be taken when installing near welders and other extreme generators of electromagnetic interference (EMI). Particular care should be taken to ensure welder currents are not injected through the marking head chassis. The marking head chassis is connected to the electrical service earth ground through the marking head cable. The marking head should be electrically isolated from all surfaces which could become part of a welder current path.

## System Software

The powerful Telesis MerlinTouch PS software is a Windows® based software package that comes installed in the TMC600 controller. It is a graphical user interface that makes pattern marking and pattern design quick and easy.

The WYSIWYG (what-you-see-is-what-you-get) interface provides a to-scale image of the pattern as it is created. The MerlinTouch PS software includes tools to create and edit a library of pattern files for marking. Each pattern contains one or more fields; each field defines a single object. Printable objects may be created to define text strings, arc-text strings, geometric shapes, graphics, and machine-readable data matrix symbols. Just “click and drag” for immediate adjustment to object size, location, or orientation. Note that for design purposes, Telesis recommends using a mouse for more precise use of the visual editing capabilities.

Printable text fields may include alphanumeric characters, symbols, and special message flags. Message flags automatically insert data into the text string, such as serial numbers, times, dates and user-defined codes. Multiple fields may be grouped and saved as a block to form a logo. Existing DXF files can also be imported for marking. Non-printable fields can be created to clearly display a graphical representation of the part being marked. Commands may be defined to perform specific tasks during the marking cycle (e.g., Pause, Go to, Input, or Output).

## Touch Screen User Interface

The top panel of the controller contains an integrated, 10-in., high resolution, touch screen monitor. The monitor displays the MerlinTouch PS software and provides the user interface for operating the marking system.



***TMC600 Controller with Touch Screen Monitor  
and MerlinTouch PS Software***



# TMP2100/600 Marking System

---

## TMC600 CONTROLLER (continued)

### Interface Panel

The back panel of the controller provides various ports for connecting the marker, host computers, logic controllers, optional accessories, and remote I/O devices. See below.

**RS-232 Interface.** The Comm 1 port allows connection to remote serial devices such as a host computer or a bar code scanner. See *Host Communications* for details.

**TTL Interface.** The TTL Port allows the system to connect with a simple contact closure circuit such as a remote push button station or foot pedal switch. These types of devices can remotely control Start Print and Stop Print operations.

**Discrete I/O Interface.** The optically-isolated I/O Port allows you to connect a Programmable Logic Controller (PLC) or other DC I/O source for remotely controlling marker operations. See *Discrete I/O Controls* for details.

**USB Interface.** The USB ports allow you to connect an optional mouse and keyboard. You may also connect a memory stick/flash drive for pattern storage and retrieval and for performing software upgrades.

**Ethernet Interface.** The Ethernet Port may be used to connect a host computer over a local area network (LAN). It allows you to define the controller as a client or a server socket using Telesis Extended Protocol. See *Host Communications* for details.

**VGA Interface.** The VGA Port allows you to connect a separate VGA monitor for troubleshooting, diagnostics, and testing. Connecting a separate monitor to operate the system is not recommended since the MerlinTouch PS software is specifically designed to display on the controller's integrated, high-resolution, touch screen monitor.

**(optional) Auxiliary Axis Interface.** The Auxiliary Axis Port allows the system to connect with two optional motion devices such as motorized tool posts, rotational drive units, and linear slides or actuators. Note that this port is available only if the optional Auxiliary Axis Driver Board is installed in the controller.

### Discrete I/O Controls

The TMC600 is configured for 12 VDC to 24 VDC I/O only and is provided to connect a PLC or other DC I/O source. The optically-isolated I/O Port allows you to remotely select and load patterns, start printing, stop printing, place the marker online, and monitor the system output signals. Cable connectors and connector pins are supplied with the controller for constructing appropriate interface cables.

**Input Signals.** These input signals provide the following controls:

INPUT COMM.....	For all inputs (+ or – supply)
START PRINT .....	Begins print cycle
STOP .....	Stops the print cycle
SEL_0 thru _6 * .....	Remotely selects & loads up to 127* patterns
SPARE_1, 2, 3.....	Three (3) spares for use with the Input command tool or for custom applications

\* System software allows SEL\_6 signal to be configured for remotely selecting patterns or for remotely placing the marker online. If used for marker online, pattern selection is reduced to 63 patterns (max).

**Output Signals.** These output signals indicate the following states:

OUTPUT COMM.....	For all outputs (+ or – supply)
DONE .....	Print cycle is complete
READY .....	System ready for message or for start print command
PAUSED .....	System paused (waiting timeout or command)
SPARE_1, 2, 3.....	Three (3) spares for use with the Output command tool or for custom applications



## Host Communications

The marking system software allows you to configure communication parameters to transmit and receive data to and from a host computer. To provide maximum integration flexibility, the system software supports RS-232 serial interfaces and Ethernet TCP/IP interfaces. The system software also provides two protocol choices: Programmable Protocol and Extended Protocol.

**RS-232 Interface.** The serial (RS-232) communications interface is most often used with remote devices such as host computers, terminals, or bar code scanners. The Comm 1 RS-232 interface supports both Telesis Extended Protocol and Telesis Programmable Protocol.

**TCP/IP Interface.** The Ethernet (TCP/IP) interface is most often used with host computers communicating over a local area network (LAN). You must use Telesis Extended Protocol with the TCP/IP interface.

The Port parameter identifies the host computer socket that is assigned to the marking system. If more than one marking system is installed in a network configuration, each system must use a separate and unique port number. The Address parameter identifies the IP address of the host computer. The marking system software supports both fixed addressing and dynamic addressing.

## Host Communications (continued)

**Programmable Protocol.** Use this protocol where very simple one-way communications are required (such as with bar code scanners). Programmable Protocol provides no error checking or acknowledgment of the transmitted data. Note that XON/XOFF Protocol applies even when Programmable Protocol is selected.

**Starting Character** specifies where the software begins to count character positions. This number must be entered in decimal format (e.g., "2" for ASCII Start of Text "STX").

**Terminating Character** identifies the end of transmitted string (usually "13" for ASCII carriage return character).

**Character Position** counted from the starting character ignoring all characters preceding it.

**Character Length** accepts variable length messages (if set to 0) or messages of a pre-specified, fixed number of characters.

**Ignore Character** identifies the character to ignore when sent from the host (usually "10" for ASCII line feed character).

**Message Type** allows message-type recognition which defines how the marking system will use data it receives from the host.

- P** Message type P loads a specific pattern identified by data extracted from host
- Q** Message type Q updates the text in the *first query buffer* with data extracted from the host
- V** Message type V updates the *first variable text flag* found in the pattern with data extracted from the host
- 0** Message type 0 (zero) indicates that host will provide message type, field number (if applicable), line number (if applicable), and data; delegates message type selection to the host on message-by-message basis. The host message must use the format:

**Tnn<string>**

where:

- T = 1, P, Q, or V to indicate message type
- nn = two-digit field number or query text buffer where data will be placed.

**Note:** Not used with Message Type P.

<string> = For Message Type P, indicates the pattern name to be loaded.

For Message Types 1, Q, or V, indicates the data to be inserted into the field or the query text buffer, as applicable.

# TMP2100/600 Marking System

## Host Communications (continued)

**Extended Protocol.** This protocol selection includes error checking and transmission acknowledgment. It should be used in applications where serial communication is a vital part of the marking operation. All communications are carried out in a parent/child relationship with the host being the parent. Only the host has the ability to initiate communications. If the host does not receive a response within three seconds, it should re-transmit its original message. If no response is received after three tries, it should declare the link to be down.

The following describes the Extended Protocol message format as sent from the host to the TMC600 controller.

**SOH TYPE [##] STX [DATA] ETX BCC CR**

where:

- SOH** ASCII Start of Header character (001H). The controller ignores all characters received prior to the SOH.
- TYPE** A single, printable ASCII character that defines the meaning (type) and content of the message downloaded from the host, where:
- P** Message Type P specifies the pattern name to be loaded for printing. See [DATA] for details.
  - Q** Message Type Q updates a specific query buffer with data supplied in the host message. See [DATA] for details.
  - V** Message Type V updates the variable text in a specific text field of the currently loaded pattern with data supplied in the host message. See [DATA] for details.
  - O** Message Type O resets marker and places it online
  - G** Message Type G initiates a print cycle to mark the currently loaded pattern
  - I** Message Type I requests the marker return the status of standard output and input signals. The system will return a hexadecimal code for the 6 output signals and 12 input signals in the following format:

**O O ; I I I**

where:

bit 1	READY	0x01
bit 2	DONE	0x02
bit 3	PAUSED	0x04
bit 4	NO_FAULT	0x08
bit 5	SPARE_1	0x10
bit 6	SPARE_2	0x20
bit 1	START	0x001
bit 2	STOP	0x002
bit 3	SEL_0	0x004
bit 4	SEL_1	0x008
bit 5	SEL_2	0x010
bit 6	SEL_3	0x020
bit 7	SEL_6 *	0x040
bit 8	SEL_4	0x080
bit 9	SEL_5	0x100
bit 10	SPARE_1	0x200
bit 11	SPARE_2	0x400
bit 12	SPARE_3	0x800

Note: Input SEL\_6 may be configured to place machine online (default) or for Remote Pattern Selection.

**[##]** Optional two-digit ASCII number that specifies the Station ID of the controller when used in multi-drop network applications. The Station ID may range from 00-31. Note that "00" is reserved for applications where only one controller is used. In such applications, this field may be eliminated and "00" will be assumed.

**STX** ASCII Start of Text Character (002H).

**[DATA]** Optional character string that may be required for certain message types (e.g., Type 1, P, Q, and V).

Typically, data is sent in the format:

**nn<string>**.

where:

nn = two-digit field number or query text buffer where data will be placed.

**Note:** Not used with Message Type P.

<string> = For Message Type P, indicates the pattern name to be loaded.

For Message Types 1, Q, or V, indicates the data to be inserted into the field or the query text buffer, as applicable.

**ETX** ASCII end of text character (003H).

**BCC** Optional Block Check Code that is generated and sent to improve link reliability by providing fault detection. The BCC is calculated by taking an eight bit addition of the TYPE and DATA TEXT characters and transmitting them as a three digit ASCII decimal number in the range from 000 to 255. If the sum is greater than 255, the most significant bit overflows and is discarded.

**CR** ASCII Carriage Return Character (00DH).

## TRADEMARKS

**Telesis**, **PINSTAMP**, and **Merlin** are registered trademarks of Telesis Technologies, Inc. in the United States.

**Atom** is a trademark of Intel Corporation in the United States and other countries.

**Intel** is a registered trademark of Intel Corporation in the United States and other countries.

**MicroPin** is a trademark of Telesis Technologies, Inc. in the United States.

**NEMA** is the registered trademark and service mark of the NATIONAL Electrical Manufacturers Association.

**Windows** and **Vista** are registered trademarks of Microsoft Corporation in the United States and other countries.